

# Inverter Driven Bearing Heater

## User's Guide

The aim of this manual is user's brief and easy understanding of overall of settings and operation. Please be sure to refer to the Instruction Manual whenever and for further information.

### Name of Parts

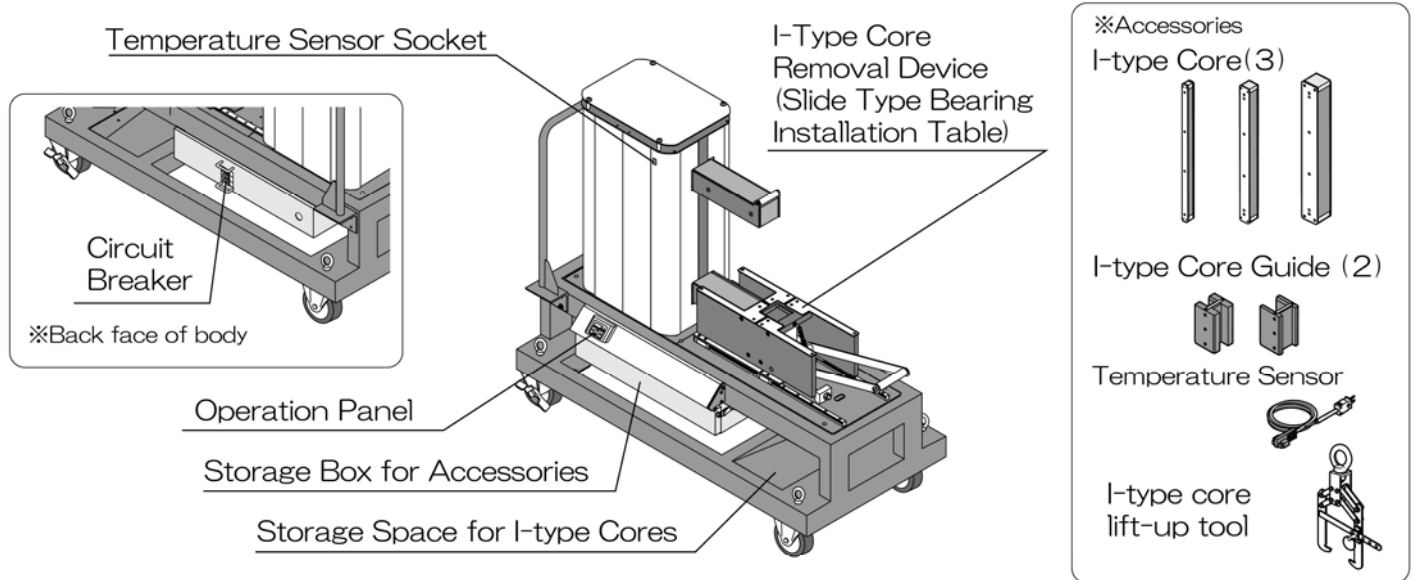

### Preparing for heating

1. Connect the power supply cable.  
※Following 'Connecting the Power supply' of the instruction manual, connect the power supply cable correctly.
2. Apply grease enough the polishing faces of I-type core and the main core.  
※The lack of the grease may cause rust, noise and vibration.

※ In the case of using the I-type core which has the guide, install the guide first.

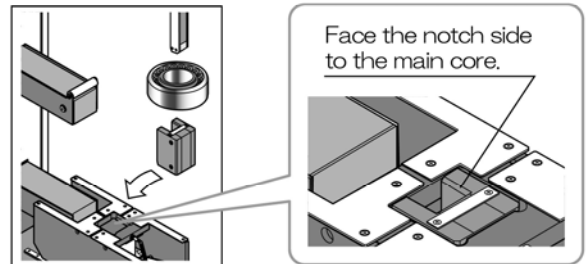

3. After placing the bearing to be heated in the I-type core removal device, install I-type core through the bore of bearing.

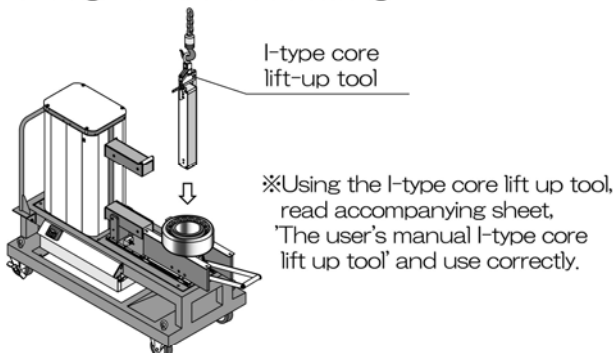

4. Slide the I-type core removal device so that the polishing faces of I-type core and the main core meet. Then set the temperature sensor.

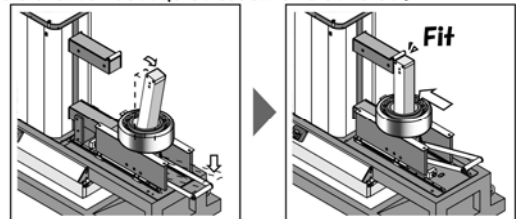

5. Turn on the circuit breaker.  
※Confirm that contact status color on the breaker. (ON→RED, OFF→GREEN)  
※The display is shown as below in this stage if the temperature sensor is not connected.



## Heating with the temperature control mode

1. Connect the temperature sensor to the sensor socket.  
Set the sensor on to the inner ring.

※ Be aware of the polarity (「+」 and 「-」) of the sensor.

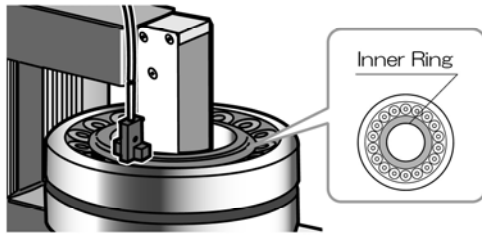

※Close up of temperature sensor

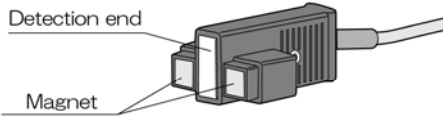

※ The control panel indicates as below when the temperature sensor was connected.  
(Default setting is 110°C.)

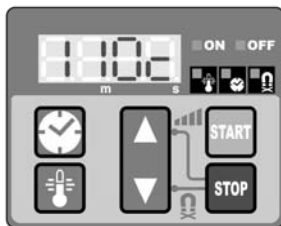

2. Push the button  , set the heating temperature.

※ If the mode is timer control mode, push the button  and set the temperature.

3. Push the button , and start heating.

4. It beeps when the set temperature is reached.  
Push the button. 

※In the temperature control mode, after the temperature reaches the set temperature, the temperature is kept (controlled) at the set temperature until STOP button is pressed.

※It starts demagnetization automatically when you put STOP button.

5. Remove the temperature sensor and slide the I-type core removal device back and remove I-type core.

6. Remove the bearing.

※Since the bearing is hot, wear the gloves.

## Heating with the timer control mode

1. Push the button , set the timer control mode.

※ The timer set range is up to 99min59sec.  
(Default setting is 0sec.)

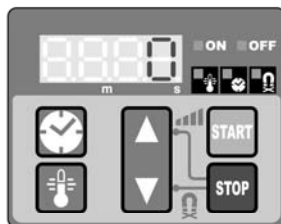

2. Push the button  , set the heating time.

3. Push the button , and start heating.

4. When the heating is done, the demagnetization starts automatically and the buzzer beeps.

5. Push the button , stop the buzzer.

6. Remove the temperature sensor and slide the I-type core removal device back and remove I-type core.

7. Remove the bearing.

※Since the bearing is hot, wear the gloves.

## Manually Demagnetization

1. Remove the temperature sensor from the bearing and push the button  and  at the same time.

Etoh Inc. [www.eto-inc.com](http://www.eto-inc.com)

Factory/Operation Office

2-2-7 Maeda YahataHigashi-ku Kitakyushu City, Fukuoka, Japan 805-0069

TEL:+81-93-681-5338 FAX:+81-93-671-3221 info@eto-inc.com